

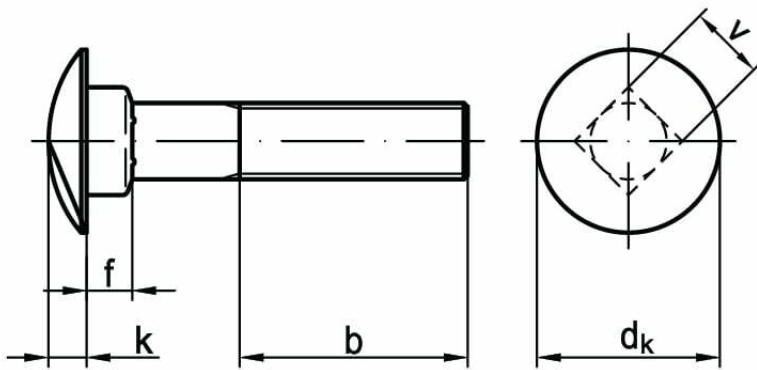

Śruby z łbem grzybkowym z podsadzeniem DIN 603, ISO 8677,
PN 82406

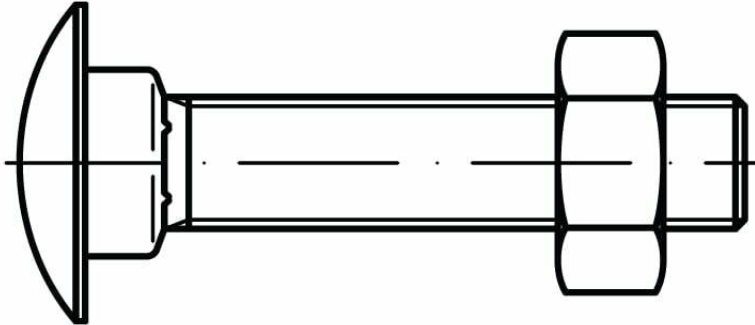

NORMA	MATERIAŁ	KLASA	POWŁOKA
DIN 603 ISO 8677 PN 82406	stal A2 A4 mosiądz	4.6 8.8	cynk galwaniczny cynk ogniowy cynk termodyfuzyjny cynk płatkowy cynk-nikiel

d	M5	M6	M8	M10	M12	M16	M20
d _k	13,5	16,55	20,65	24,65	30,65	38,8	46,8
k	3,3	3,88	4,88	5,38	6,95	8,95	11,05
f	4,1	4,6	5,6	6,6	8,75	12,9	15,9
v	5,48	6,48	8,58	10,58	12,7	16,7	20,84
b l<125	16	18	22	26	30	38	46
b 125<l<200	22	24	28	32	36	44	52
b l>200	–	–	41	45	49	57	65