

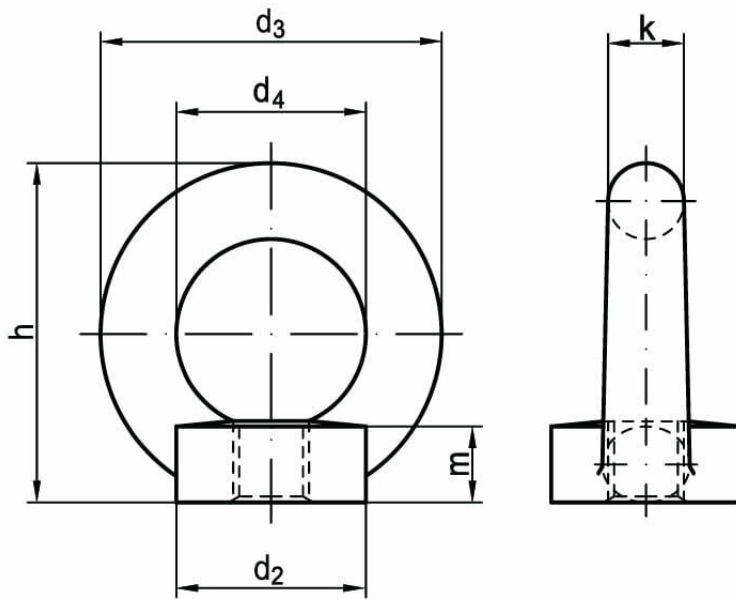

# Nakrętka z uchem DIN 582

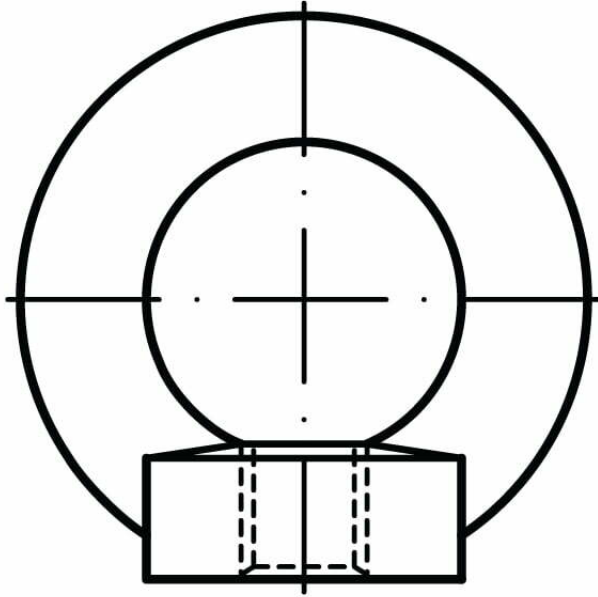

| NORMA   | MATERIAŁ        | KLASA | POWŁOKA                                 |
|---------|-----------------|-------|---|
| DIN 582 | C15<br>A2<br>A4 |       | cynk galwaniczny<br>cynk termodyfuzyjny |

| d              | M6  | M8  | M10 | M12 | M14 | M16 | M18 |
|----------------|-----|-----|-----|-----|-----|-----|-----|
| d <sub>2</sub> | 17  | 20  | 25  | 30  | 35  | 35  | 40  |
| d <sub>3</sub> | 28  | 36  | 45  | 54  | 63  | 63  | 72  |
| d <sub>4</sub> | 16  | 20  | 25  | 30  | 35  | 35  | 40  |
| m              | 8,5 | 8,5 | 10  | 11  | 13  | 13  | 16  |
| h              | 31  | 36  | 45  | 53  | 62  | 62  | 71  |
| k              | 6   | 8   | 10  | 12  | 14  | 14  | 16  |

| d              | M20 | M22  | M24 | M27 | M30 | M33 | M36 |
|----------------|-----|------|-----|-----|-----|-----|-----|
| d <sub>2</sub> | 40  | 45   | 50  | 50  | 65  | 65  | 75  |
| d <sub>3</sub> | 72  | 81   | 90  | 90  | 108 | 108 | 126 |
| d <sub>4</sub> | 40  | 45   | 50  | 50  | 60  | 60  | 70  |
| m              | 16  | 18   | 20  | 20  | 25  | 25  | 30  |
| h              | 71  | 80,5 | 90  | 90  | 109 | 109 | 128 |
| k              | 16  | 18   | 20  | 20  | 24  | 24  | 28  |

| d              | M39 | M42 | M45 | M48 | M52 | M56 | M64 |
|----------------|-----|-----|-----|-----|-----|-----|-----|
| d <sub>2</sub> | 85  | 85  | 100 | 100 | 110 | 110 | 120 |
| d <sub>3</sub> | 144 | 144 | 166 | 166 | 184 | 184 | 206 |
| d <sub>4</sub> | 80  | 80  | 90  | 90  | 100 | 100 | 110 |
| m              | 35  | 35  | 40  | 40  | 45  | 45  | 50  |
| h              | 147 | 147 | 168 | 168 | 187 | 187 | 208 |
| k              | 32  | 32  | 38  | 38  | 42  | 42  | 48  |