

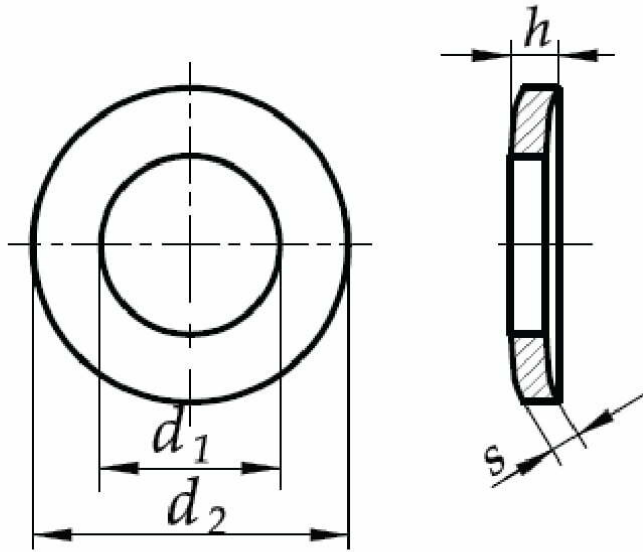

# Podkładki podatne stożkowe SCHNORR typ HS



NORMA	MATERIAŁ	KLASA	POWŁOKA
	stal		wg wytycznych klienta

d	M6	M8	M10	M12	M14	M16	M18	M20
d <sub>1</sub>	6,4	8,4	10,5	13	15	17	19	21
d <sub>2</sub>	12	17	21	24	28	30	33	36
h min	1,64	2,1	2,75	3,27	3,8	4,31	4,8	5,3
h max	1,9	2,55	3,15	3,75	4,35	4,95	5,5	5,95
s	1,5	2,0	2,5	3,0	3,5	4,0	4,5	5,0

d	M22	M24	M27	M30
d <sub>1</sub>	23	25	28	31
d <sub>2</sub>	40	45	50	58
h min	5,9	6,45	7,0	7,65
h max	6,7	7,3	8,0	8,9
s	5,5	6,0	6,5	7,0