

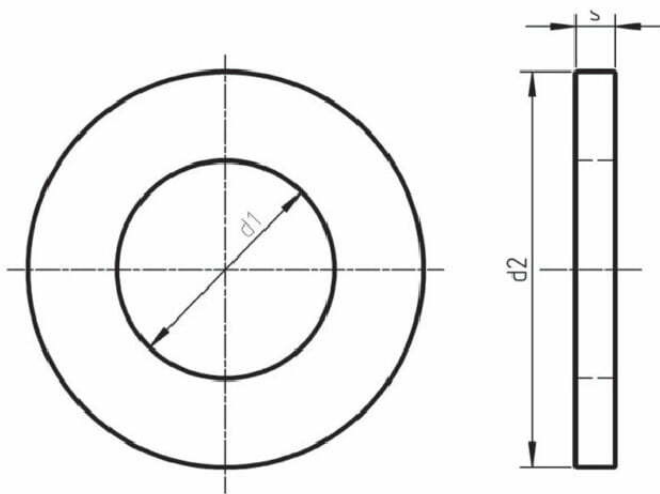

Podkładki okrągłe zgrubne DIN 126, ISO 7091, PN 82005

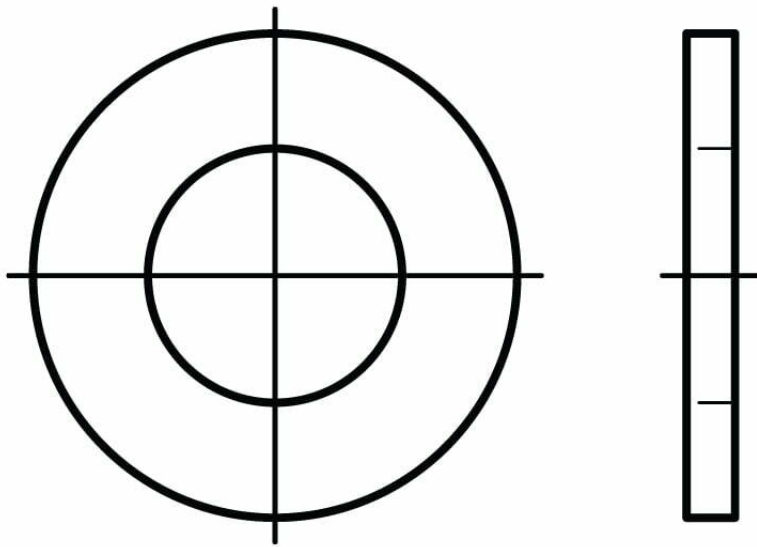

NORMA	MATERIAŁ	KLASA	POWŁOKA
DIN 126 ISO 7091 PN 82005	stal	100 HV	ocynk galwaniczny

d <sub>nom</sub>	M5	M6	M7	M8	M10	M12	M14	M16
d <sub>1</sub>	5,5	6,6	7,6	9	11	13,5	15,5	17,5
d <sub>2</sub>	10	12	14	16	20	24	28	30
s	1	1,6	1,6	1,6	2	2,5	2,5	3

d <sub>nom</sub>	M18	M20	M22	M24	M27	M30	M33	M36
d <sub>1</sub>	20	22	24	26	30	33	36	39
d <sub>2</sub>	34	37	39	44	50	56	60	66
s	3	3	3	4	4	4	5	5

d <sub>nom</sub>	M39	M42	M45	M48	M52	M56	M60	M64
d <sub>1</sub>	42	45	48	52	56	62	66	70
d <sub>2</sub>	72	78	85	92	98	105	110	115
s	6	8	8	8	8	10	10	10

d <sub>nom</sub>	M72	M80						
d <sub>1</sub>	78	86						
d <sub>2</sub>	125	140						
s	10	12						