

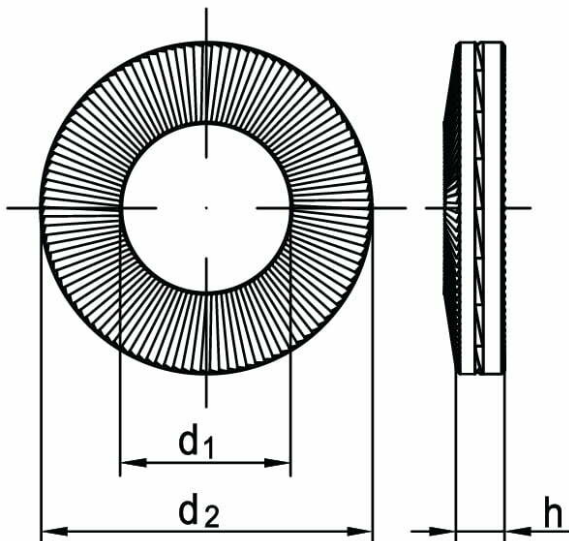

Podkładki samoklinujące Nord Lock

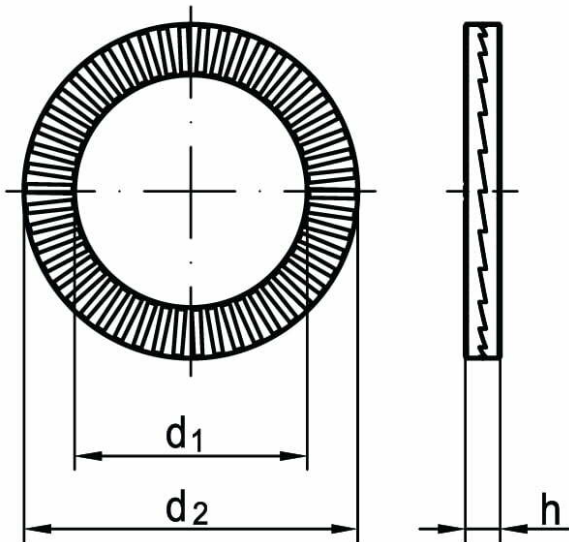
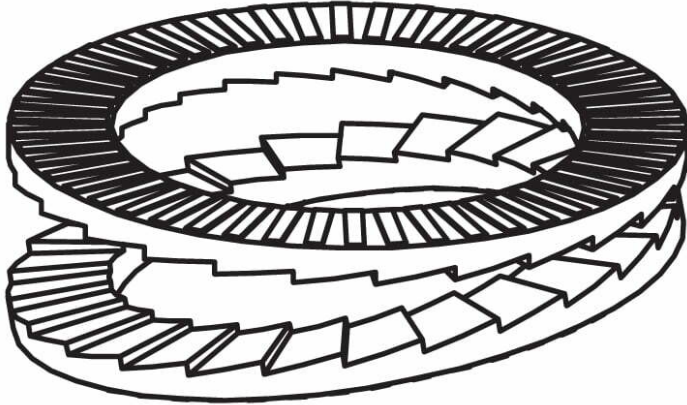

NORMA	MATERIAŁ	KLASA	POWŁOKA
	stal A4		cynk galwaniczny cynk termodyfuzyjny

d	M3	M3,5	M4	M5	M6	M8	M10	M12
d ₁	3,4	3,9	4,4	5,4	6,5	8,7	10,7	13,0
d ₂	7,0	7,6	7,6	9,0	10,8	13,5	16,0	19,5
t	2,2	2,2	2,2	2,2	2,2	2,2	2,2	2,2

d	M14	M16	M18	M20	M22	M24	M27	M30
d ₁	15,2	17,0	19,5	21,4	23,4	25,3	28,4	31,4
d ₂	23,0	25,4	29,0	30,7	34,5	39,0	42,0	47,0
t	3,2	3,2	3,2	3,2	3,2	3,2	6,8	6,8

d	M33	M36	M39	M42	M45	M48	M52	M56
d ₁	34,4	37,4	40,4	43,2	46,2	49,6	53,6	59,1
d ₂	48,5	55,0	58,5	63,0	70,0	75,0	80,0	85,0
t	6,8	6,8	6,8	6,8	9,0	9,0	9,0	9,0