

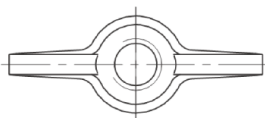

Nakrętki skrzydełkowe DIN 315

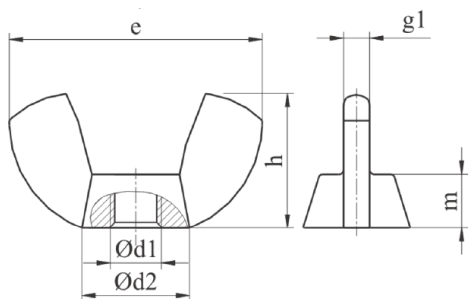
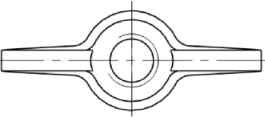
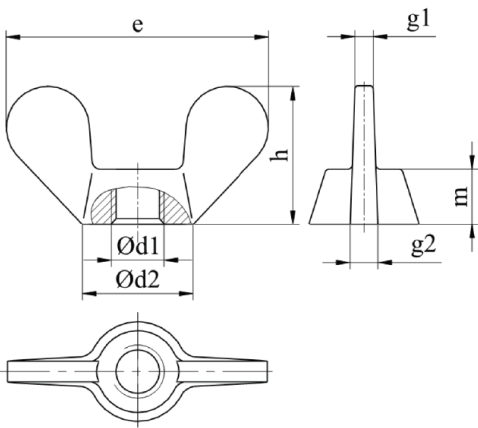
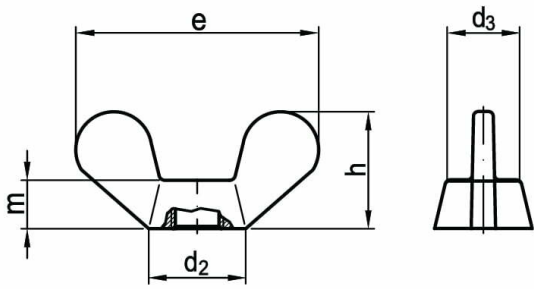
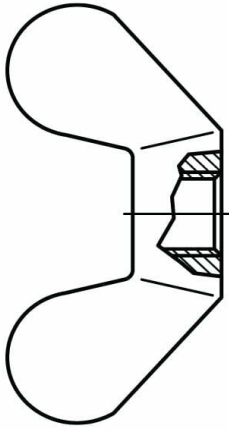

NORMA	MATERIAŁ	KLASA	POWŁOKA
DIN 315 ~ DIN 315	stal A2 A4 mosiądz		ocynk galwaniczny

		~ DIN 315					DIN 315			
<i>d</i>		M4	M5	M6	M8	M10	M12	M16	M20	M24
<i>P</i>		0,7	0,8	1	1,25	1,5	1,75	2	2,5	3
<i>d</i> ₂	max	8	11	13	16	20	23	29	35	44
	min	6	8	10	13	17	20	26	32	41
<i>e</i>	max	20	26	33	39	51	65	73	90	110
	min	18	24	30	36	48	62	70	86	106
<i>g</i> ₁	max	1,9	2,3	2,3	2,8	4,4	4,9	6,4	6,9	9,4
	min	1,1	1,5	1,5	2	3,6	4,1	5,6	6,1	8,6
<i>g</i> ₂	max	2,3	2,8	3,3	4,4	5,4	6,4	7,5	8	10,5
	min	1,7	2,3	2,7	3,6	4,6	5,6	6,5	7	9,5
<i>h</i>	max	10,5	13	17	20	25	33,5	37,5	46,5	56,5
	min	8,5	11	15	18	23	31	35	44	53,5
<i>m</i>	max	4,6	6,5	8	10	12	14	17	21	25
	min	3,2	4	5	6,5	8	10	13	16	20

P – podziałka gwintu