

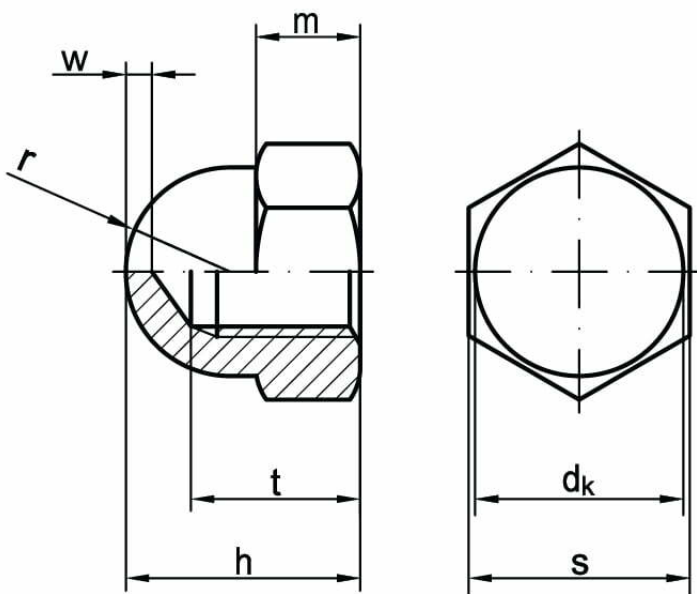

Nakrętki kołpakowe DIN 1587, PN 82181

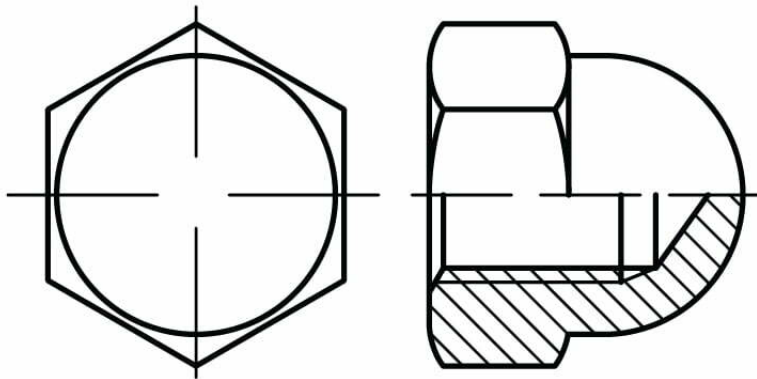

NORMA	MATERIAŁ	KLASA	POWŁOKA
DIN 1587 PN 82181	stal A2 A4 mosiądz	6 8	cynk galwaniczny cynk-nikiel

d	M3	M4	M5	M6	M8	M10	M12	M14
d _k	5,8	6,5	7,5	9,5	12,5	15	17	20
h	5,5	8	10	12	15	18	22	25
m	2,4	3,2	4	5	6,5	8	10	11
s	5,5	7	8	10	13	17	19	22
t	4,5	5,26	7,21	7,71	10,65	12,65	15,65	17,65
w	2	2	2	2	2	2	3	4

d	M16	M18	M20	M22	M24	M27	M30	
d _k	23	26	28	33	34	39	44	
h	28	32	34	39	42	46	50	
m	13	15	16	18	19	22	24	
s	24	27	30	34	36	41	46	
t	20,58	24,58	25,58	28,58	30,5	35	39	
w	4	5	5	5	6	7	7	