

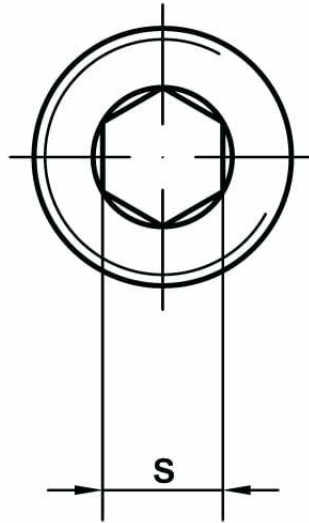

Korki gwintowane z gniazdem sześciokątnym z gwintem stożkowym DIN 906

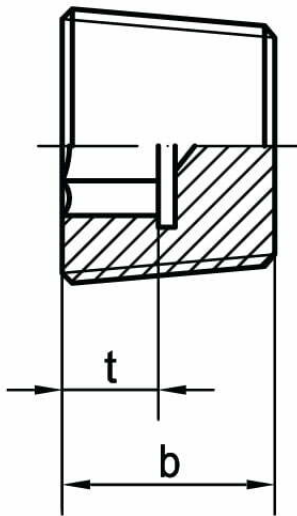
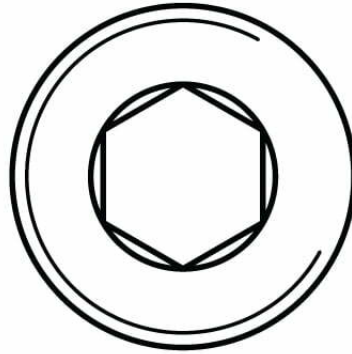
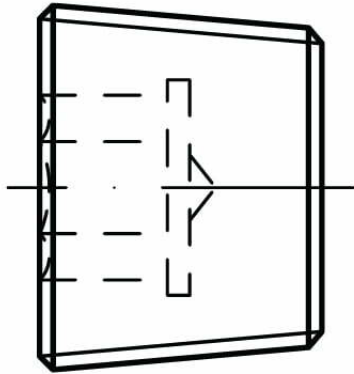

NORMA	MATERIAŁ	KLASA	POWŁOKA
DIN 906	stal A4 mosiądz		bez pokrycia ocynk płytkowy

$d^{1)}$	M8x1	M10x1	M12x1,5	(M14x1,5)	M16x1,5	M18x1,5	M0x1,5
b_{js16}	8	8	10	10	10	10	10
t_{min}	4	4	5	5	5	5	5
s_{D12}	4	5	6	7	8	8	10

$d^{1)}$	M22x1,5	M24x1,5	M26x1,5	M27x2	M30x1,5		
b	10	12	12	12	12		
t_{min}	5	6	6	6	6		
s	10	12	12	12	17		

$d^{2)}$	R1/8	R1/4	R3/8	R1/2	R3/4	R1	R1 1/4
b_{js16}	8	10	10	10	12	12	18
t_{min}	4	5	5	5	6	6	11,5
s_{D12}	5	7	8	10	12	17	22

1) – gwint metryczny wg DIN 158
2) – gwint rurowy Withwortha wg DIN 3858
– tolerancja 2 (wersja skrócona)