

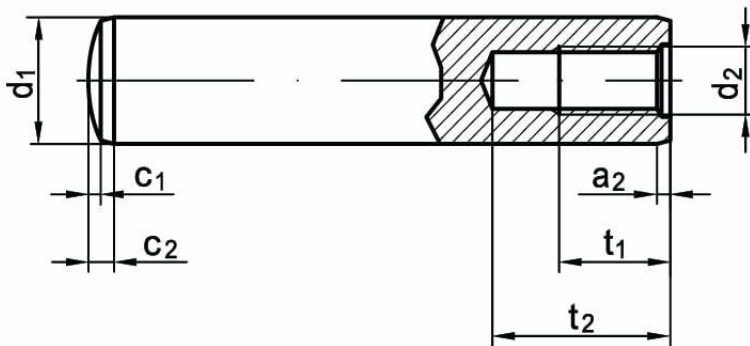

Kołki walcowe hartowane z gwintem wewnętrznym DIN 7979 D,
tolerancja m6, ISO 8735, PN 85018



NORMA	MATERIAŁ	KLASA	POWŁOKA
DIN 7979 D ISO 8735 PN 85018	stal		

d_1	4*	5*	6	8	10	12	14	16
a_2	0,5	0,6	0,8	1	1,2	1,6	1,8	2
c_1	0,4	0,5	0,6	0,8	1	1,2	1,4	1,6
c_2	1,3	1,7	2,1	2,6	3	3,8	4	4,7
d_2	(M 2)	(M 3)	M 4	M 5	M 6	M 6	M 8	M 8
t_1	6	6	6	8	10	10	12	12
$t_{2\ min}$	7	7	10	12	16	16	20	20

d_1	20	25	30	40				
a_1	2,5	3	4	5				
c_1	2	2,5	3	4				
c_2	6	6	7	8				
d_2	M 10	M 16	M 20	M 20				
t_1	16	24	30	30				
$t_{2\ min.}$	25	34	42	42				