

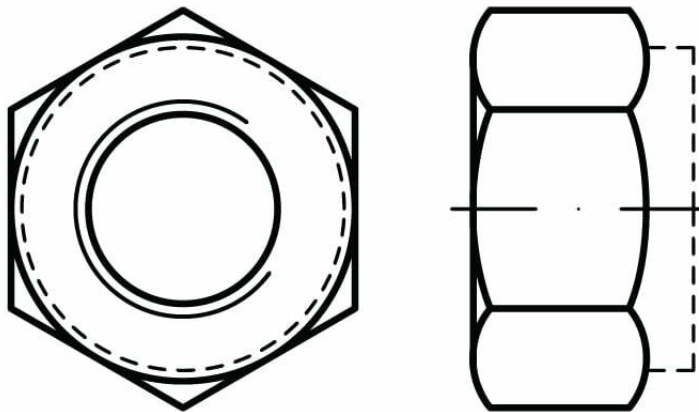

Self-Locking Nuts w/nylon Insert: Heavy Series DIN 982

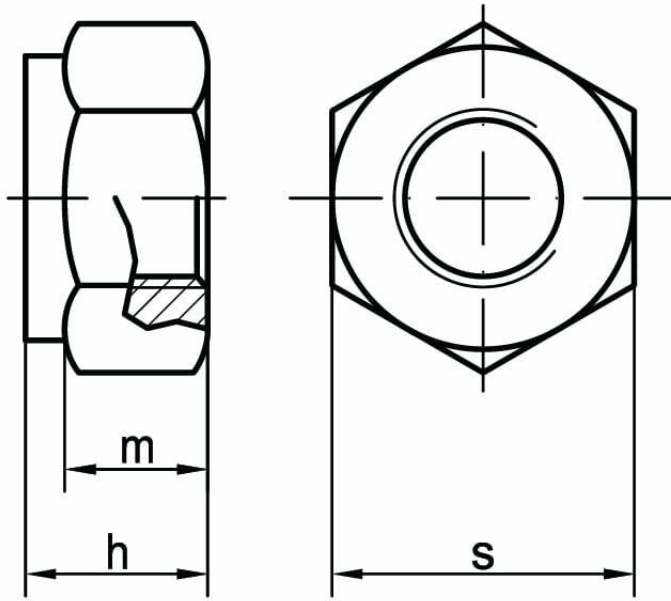

STANDARD	MATERIAL	CLASS	COATING
DIN 6924 DIN 982 ISO 7040 ISO 10512 PN 82175	stal A2 A4	5 6 8 10	cynk galwaniczny

d	M3	M4	M5	M6	M8	M10	M12	M14
h	4,5	6	6,8	8	9,5	11,9	14,9	17
s _{DIN/ISO}	5,5	7	8	10	13	16	18	21

d	M16	M18	M20	M22	M24	M27	M30	M33
h	19,1	20,6	22,8	24,5	27,1	31	32,6	35,5
s _{DIN/ISO}	24	27	30	34	36	41	46	50

d	M36	M39	M42	M45	M48
h	38,9	42	45	48	50
s _{DIN/ISO}	55	60	65	70	75