

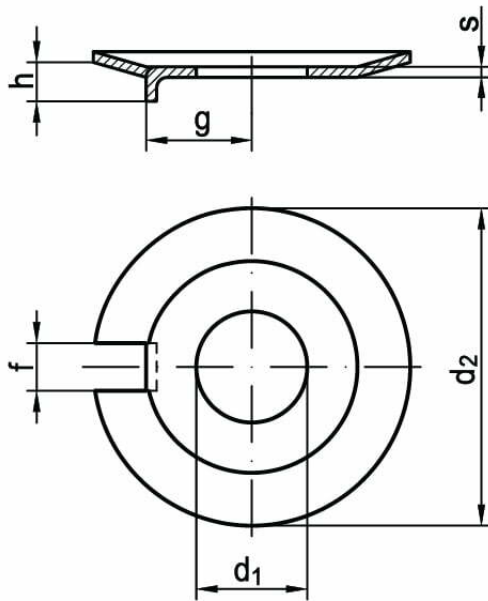

Washers with external tap DIN 432

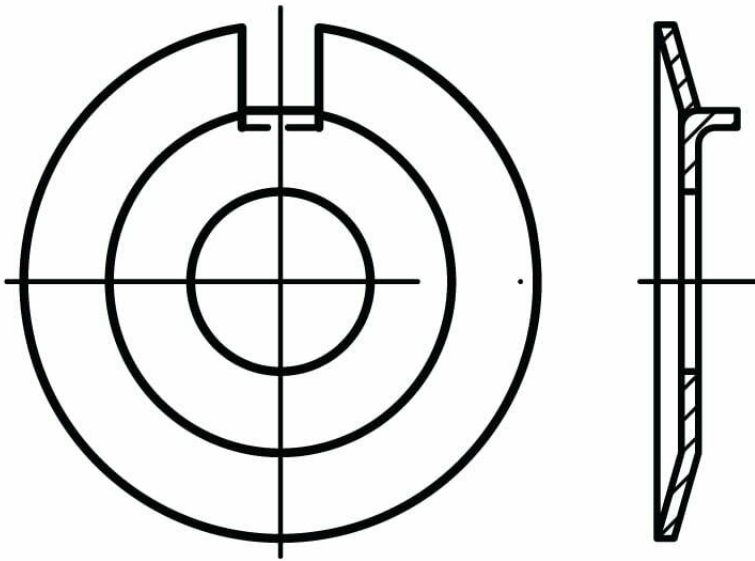

STANDARD	MATERIAL	CLASS	COATING
DIN 432 PN 82011	steel A2 A4 brass copper		galvanized zinc

d	M3	M3,5	M4	M5	M6	M8	M10	M12
d ₁	3,2	3,7	4,3	5,3	6,4	8,4	10,5	13,0
d ₂	12	12	14	17	19	22	26	30
f	2,5	2,5	2,5	3,5	3,5	3,5	4,5	4,5
g	4,5	4,5	5,5	7,0	7,5	8,5	10	12
h	2	2	2	2,5	3	4	4	4,5
s	0,4	0,4	0,4	0,75	0,75	1	1	1,2

d	M14	M16	M18	M20	M22	M24	M27	M30
d ₁	15	17	19	21	23	25	28	31
d ₂	33	36	40	42	50	50	58	63
f	4,5	5,5	6,5	6,5	7,5	7,5	8,5	8,5
g	13	15	18	18	20	21	23	25
h	4,5	4,5	4,5	4,5	6,5	6,5	9,5	9,5
s	1,2	1,2	1,2	1,6	1,6	1,6	1,6	1,6

d	M33	M36	M39	M42	M45	M48	M52	
d ₁	34	37	40	43	46	50	54	
d ₂	68	75	82	88	95	100	105	
f	9,5	11	11	11	13	13	13	
g	28	31	33	36	38	40	42	
h	9,5	9,5	11	11	12	13	13	
s	1,6	2	2	2	2	2	2	