

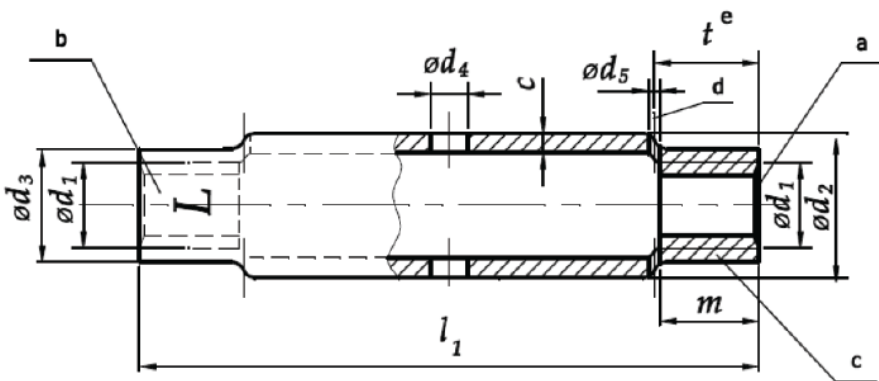

Turnbuckle frame DIN 1478

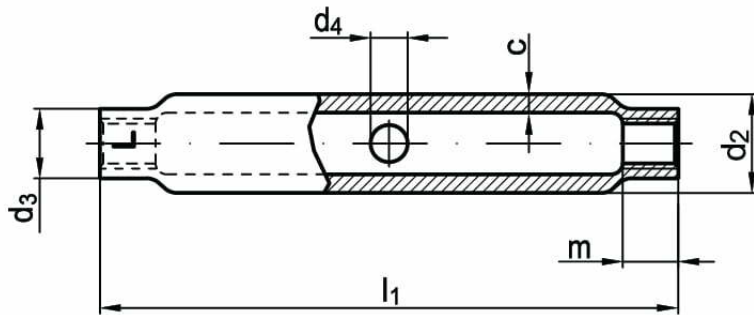
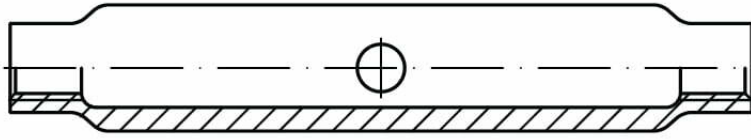

STANDARD	MATERIAL	CLASS	COATING
DIN 1478 PN 82268	S235 S355 A2 A4		galvanized zinc hot-dip galvanized zinc

TURNBUCKLE FRAME WITH STUBS DIN 1478

TURNBUCKLE FRAME DIN 1478

d	M6	M8	M10	M12	M16	M20	M24	M30	M36
d ₂	17,2	17,2	21,3	25,0	30,0	33,7	42,4	51	63,5
d ₃	9	12	15	18	22,5	27	32	38	47,5
D	6	8	8	10	10	12	12	16	16
c	2,9	3,6	4	4	4,5	5	5,6	6,3	8
l ₁	110	110	125	125	170	200	255	255	295
m	7,5	10	12	15	20	24	29	36	43
range tensioning	90	85	95	90	120	140	180	160	180