

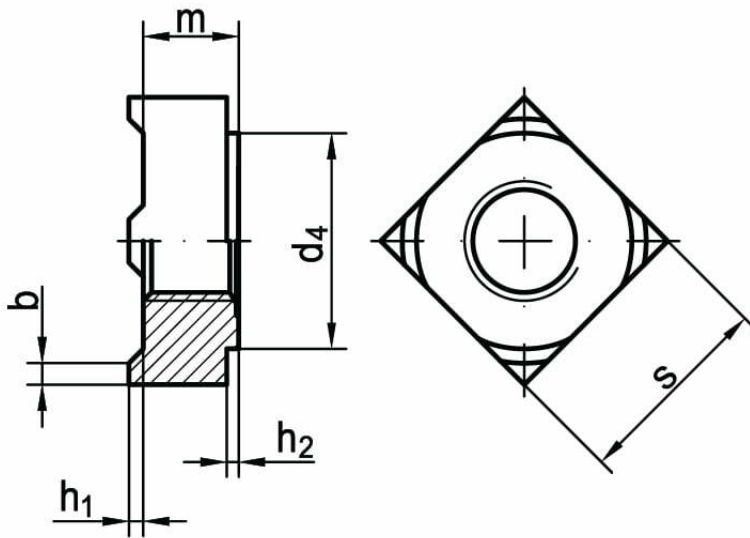

Square weld nuts DIN 928

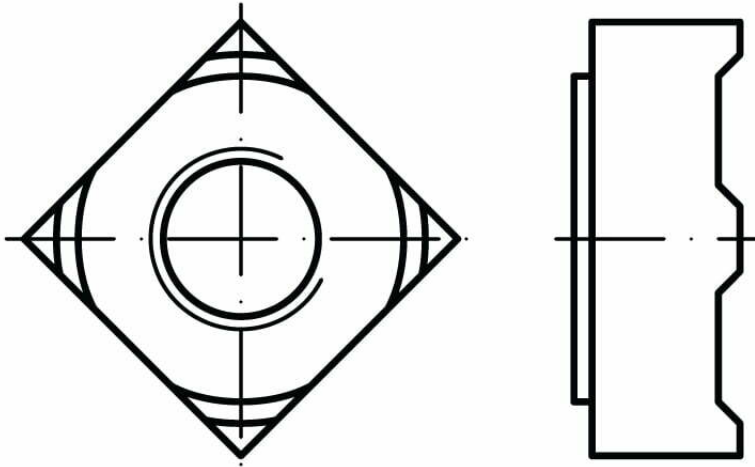

STANDARD	MATERIAL	CLASS	COATING
DIN 928 PN 82169	steel A2	5	

d	M4	M5	M6	M8	M10	M12	M14	M16
$d_{4\min}$	6,4	8,2	9,1	12,8	15,6	17,4	20,4	22,4
h_1	0,6	0,8	0,8	1,0	1,2	1,4	1,4	1,6
$h_{2\min}$	0,4	0,6	0,7	1,1	1,25	1,75	1,75	2,0
m	3,5	4,2	5,0	6,5	8,0	9,5	11,4	13,0
s	7	9	10	14	17	19	22	24