

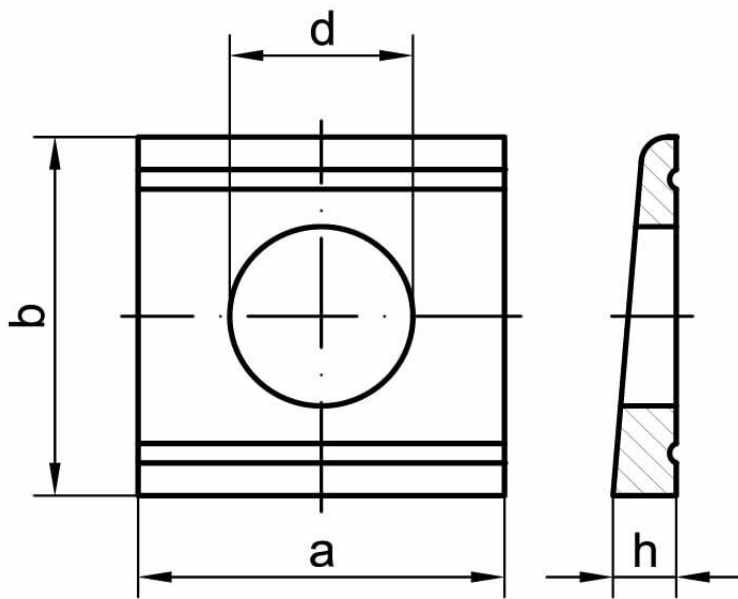

# Square beveled washer (8% taper) DIN 434

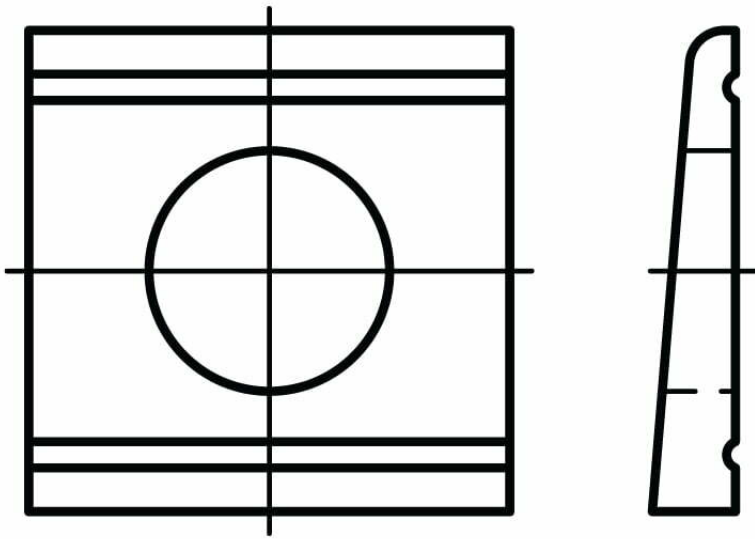

STANDARD	MATERIAL	CLASS	COATING
DIN 434 PN 82018	steel A2 A4		galvanized zinc hot-dip galvanized zinc thermo-diffusion zinc coating lamellar coatings (flake) zinc-nickel

	M8	M10	M12	M16	M20	M22	M24	M27
d	9	11	14	18	22	24	26	30
a	22	22	26	32	40	44	56	56
b	22	22	30	36	44	50	56	56
h	3,8	3,8	4,9	5,9	7	8	8,5	8,5
8% taper								