

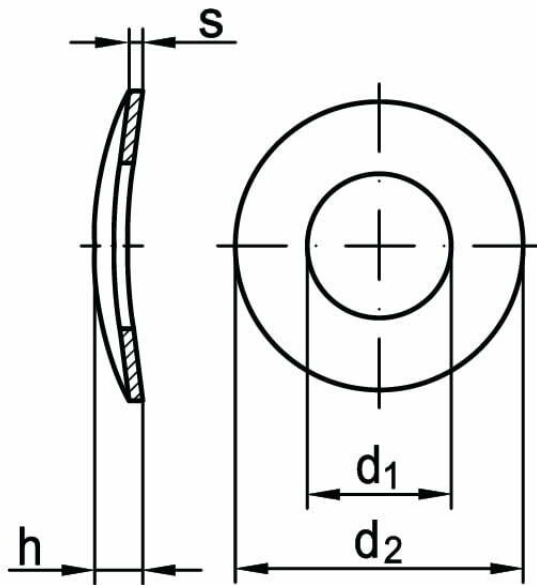

Spring washer, waved DIN 137 B

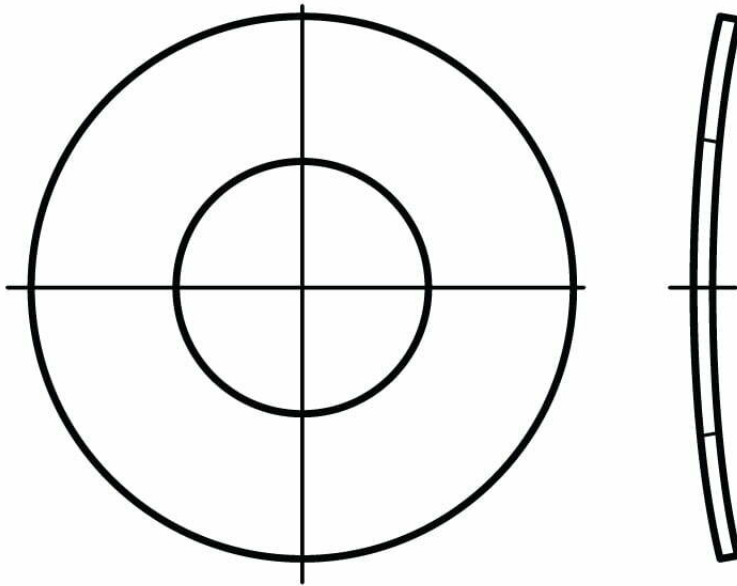

STANDARD	MATERIAL	CLASS	COATING
DIN 137 B PN 82037	steel A2 A4		galvanized zinc

DIN 137 A – Spring Washer, Curved
DIN 137 B – Spring Washer, Waved

d	M3	M3,5	M4	M5	M6	M7	M8	M10
d ₁	3,2	3,7	4,3	5,3	6,4	7,4	8,4	10,5
d ₂	8	8	9	11	12	14	15	21
s	0,5	0,5	0,5	0,5	0,5	0,8	0,8	1
h	1,6	1,8	2,0	2,2	2,6	3,0	3,0	4,2

d	M12	M14	M16	M18	M20	M22	M24	M27
d ₁	13	15	17	19	21	23	25	28
d ₂	24	28	30	34	36	40	44	50
s	1,2	1,6	1,6	1,6	1,6	1,8	1,8	2,0
h	5	6	6,4	6,6	7,4	7,8	8,2	9,4

d	M30	M33	M36	M39	M42	M45	M48	M52
d ₁	31	34	37	40	43	46	50	54
d ₂	56	60	68	72	78	85	92	98
s	2,2	2,2	2,5	2,8	3,0	3,0	3,5	3,5
h	10	10,6	11,6	12,8	13,6	14,2	15,6	16,4