

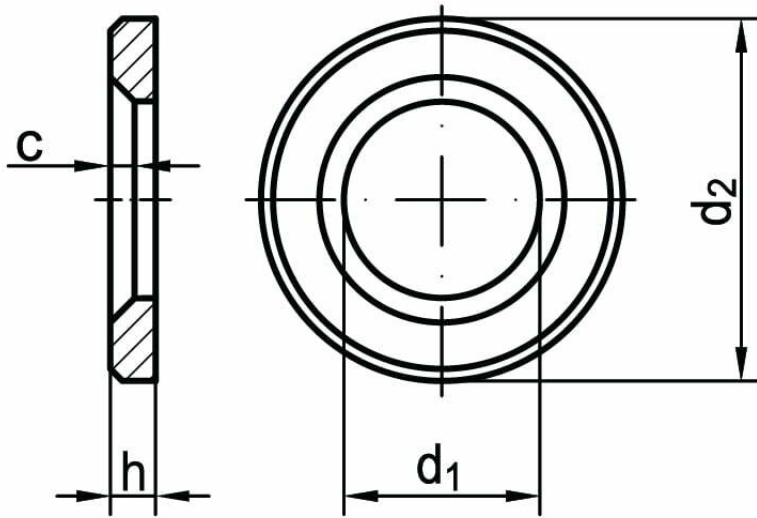

High-strength injection structural washers DIN 6916

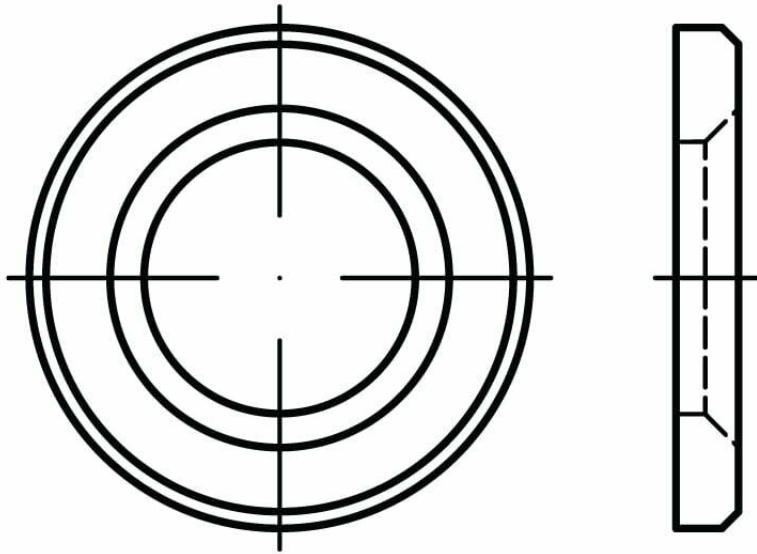

STANDARD	MATERIAL	CLASS	COATING
DIN 6916 PN 82039 ISO 14399 / ISO 7416 EN 14399-6	steel	HV	hot-dip galvanized zinc

d	M12	M16	M20	M22	M24	M27	M30	M36
$d_{1\min}$	13	17	21	23	25	28	31	37
$d_{2\max}$	24	30	37	39	44	50	56	66
h	3	4	4	4	4	5	5	5
c_{\min}	1,6	1,6	2	2	2	2,5	2,5	2,5