

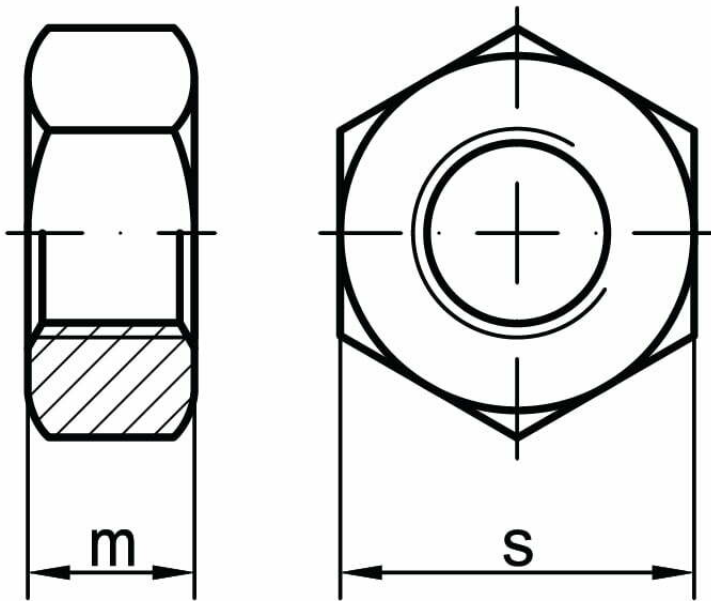

High-strength injection structural nuts DIN 6915

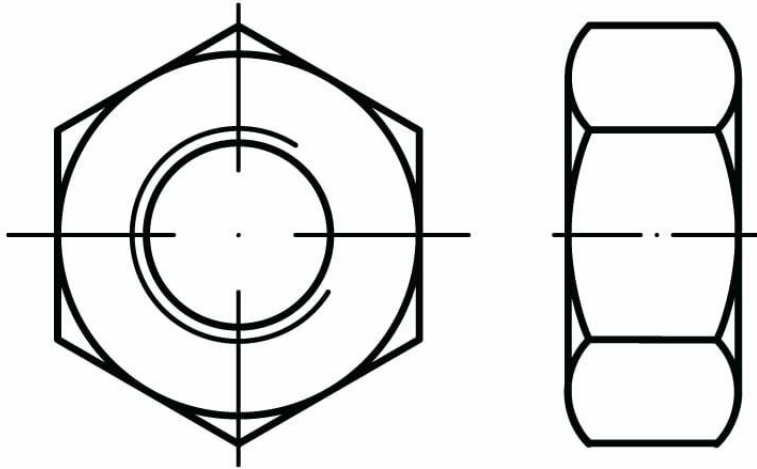

STANDARD	MATERIAL	CLASS	COATING
DIN 6915 PN 82171 ISO 14399 / ISO 7414 EN 14399-4	steel	10.9	hot-dip galvanized zinc

d	M12	M16	M20	M22	M24	M27	M30	M36
m	10	13	16	18	20	22	24	29
s	22	27	32	36	41	46	50	60