

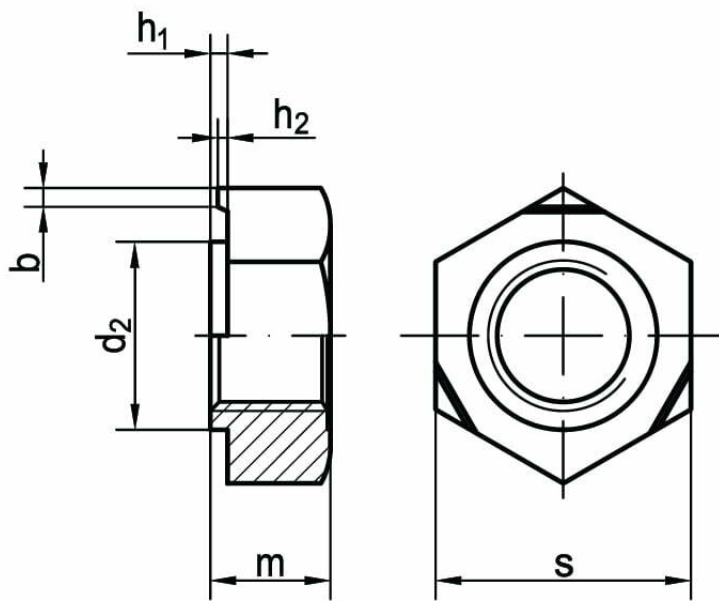

Hexagon weld nuts DIN 929

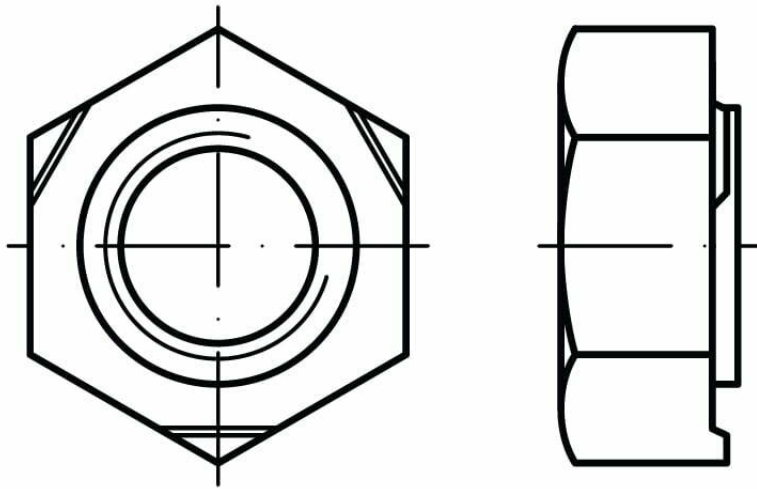

STANDARD	MATERIAL	CLASS	COATING
DIN 929 PN 82169	steel A2 A4	5	

d	M3	M4	M5	M6	M8	M10	M12	M14	M16
d ₂	4,5	6	7	8	10,5	12,5	14,8	16,8	18,8
h _{1 max}	0,55	0,65	0,7	0,75	0,9	1,15	1,4	1,8	1,8
h _{2 max}	0,25	0,35	0,4	0,4	0,5	0,65	0,8	1,0	1,0
m	3	3,5	4	5	6,5	8	10	11	13
s	7,5	9	10	11	14	17	19	22	24